

— PROPRIETARY —
 THIS DOCUMENT CONTAINS CONFIDENTIAL, PROPRIETARY INFORMATION THAT IS FOX PROPERTY. DO NOT DISCLOSE TO OR DUPLICATE FOR OTHERS EXCEPT AS AUTHORIZED BY FOX.

REVISIONS				
ZONE	REV	DESCRIPTION	DATE	APPROVED
	A	RELEASE TO PRODUCTION	2023-08-21	NL/BS
	B	CHANGED PISTON, O-RING AND VALVING	2023-12-23	NL/BS

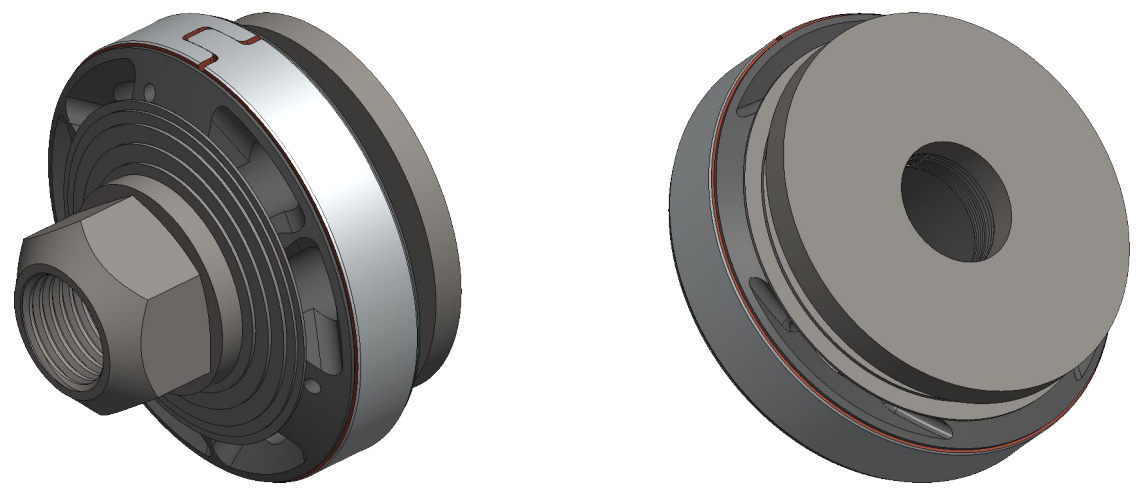

ISOMETRIC VIEW

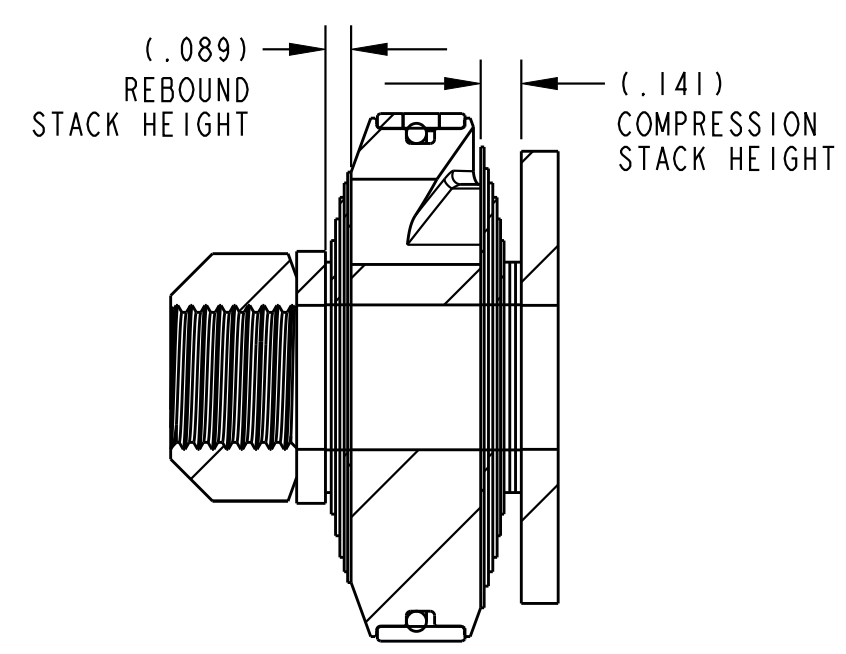
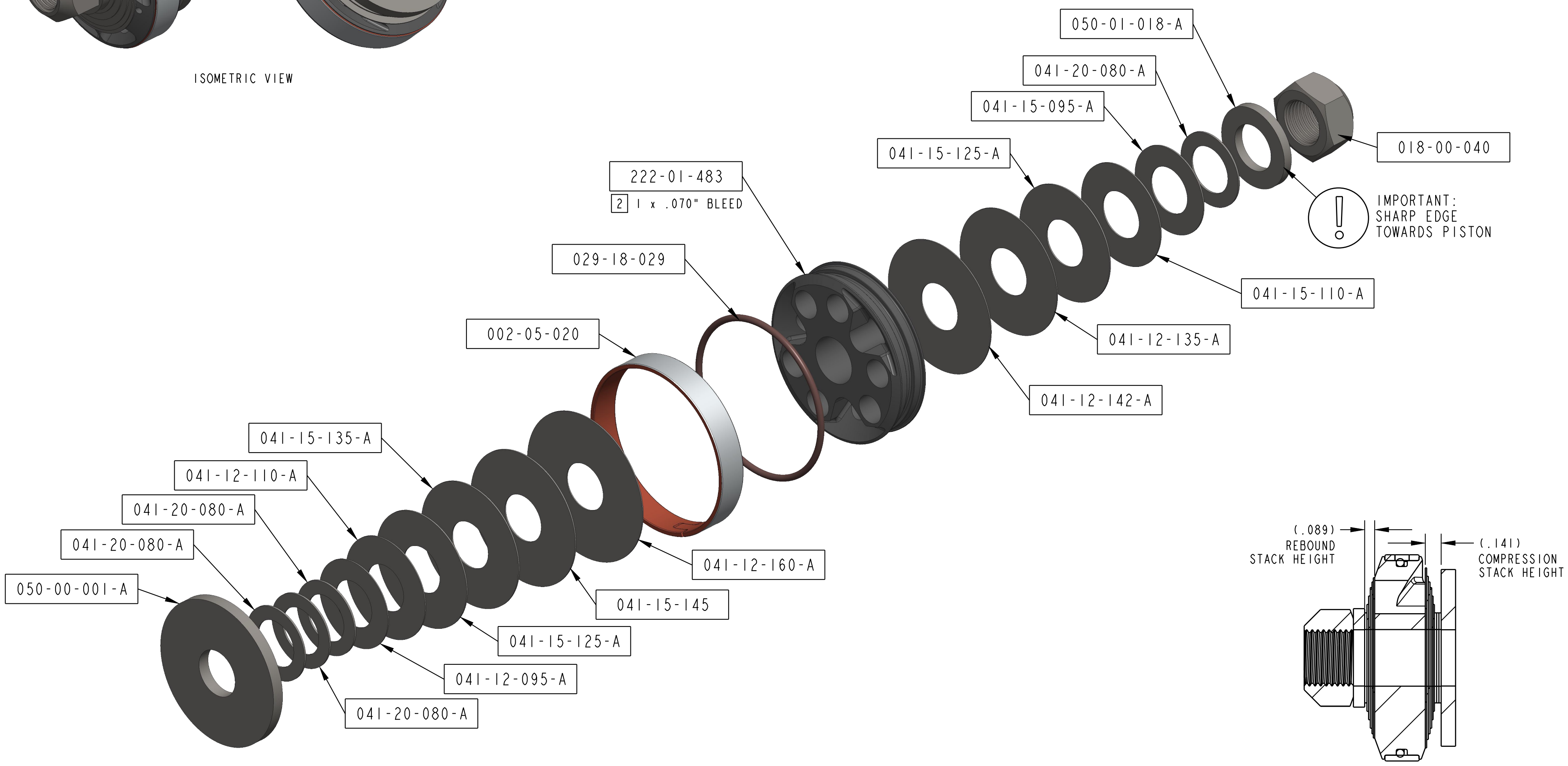

NOTES:
 1. APPLICATION: CLASS II REAR SHOCKS
 2 DRILL QTY 1, .070" BLEED

UNLESS OTHERWISE SPECIFIED DRAWING PER ASME Y14.100-2017 DIMENSIONS ARE SHOWN IN INCHES [MM] TOLERANCES DECIMALS .XX [.X] ±.01 [0,25] .XXX [.XX] ±.005 [0,13] ANGLES ±1° THIRD ANGLE PROJECTION	APPROVALS	DATE	FOX Factory, Inc. 2055 Sugarloaf Circle, Suite 300 Duluth, Ga 30097 USA Phone 800-369-7469	TITLE VALVING ASSEMBLY: 2.0 FACTORY SERIES, TUNED COMBINATION 058	
	DRAWN BY	N LEONE			2023-08-21
	CHECKED	B SMITH			2023-08-21
	ENGINEER	N LEONE	2023-08-21	SIZE	DWG. NO.
	DEV PROJECT #: N/A		C	807-24-058	REV
	PROTO / MAKE FROM PN: N/A		PLOT SCALE: 1.35:1		B
				SHEET: 1 OF 2	

4

3

2

1

— PROPRIETARY —
 THIS DOCUMENT CONTAINS CONFIDENTIAL, PROPRIETARY
 INFORMATION THAT IS FOX PROPERTY. DO NOT DISCLOSE TO
 OR DUPLICATE FOR OTHERS EXCEPT AS AUTHORIZED BY FOX.

D

D

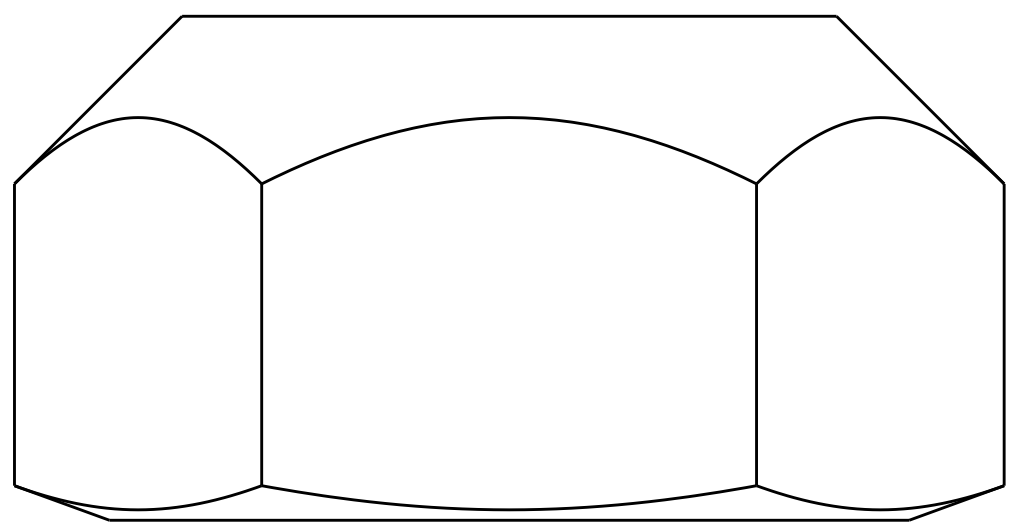

BACK-UP WASHER

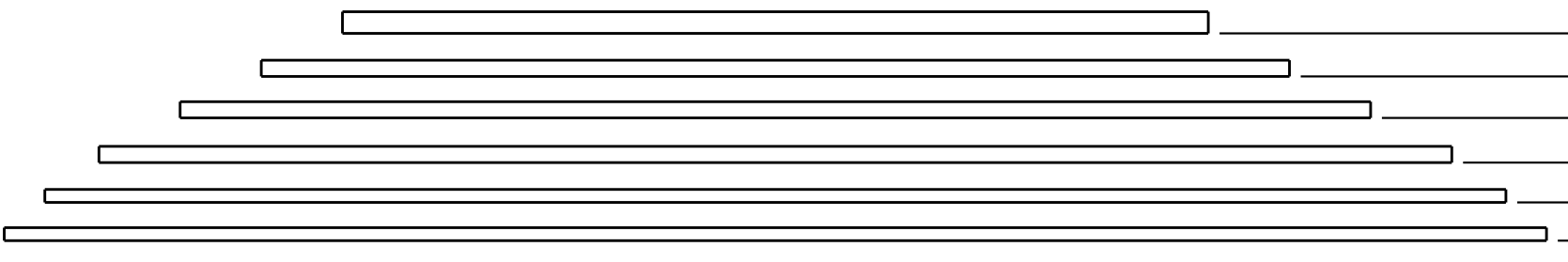

- .800 X .020
- .950 X .015
- 1.100 X .015
- 1.250 X .015
- 1.350 X .012
- 1.425 X .012

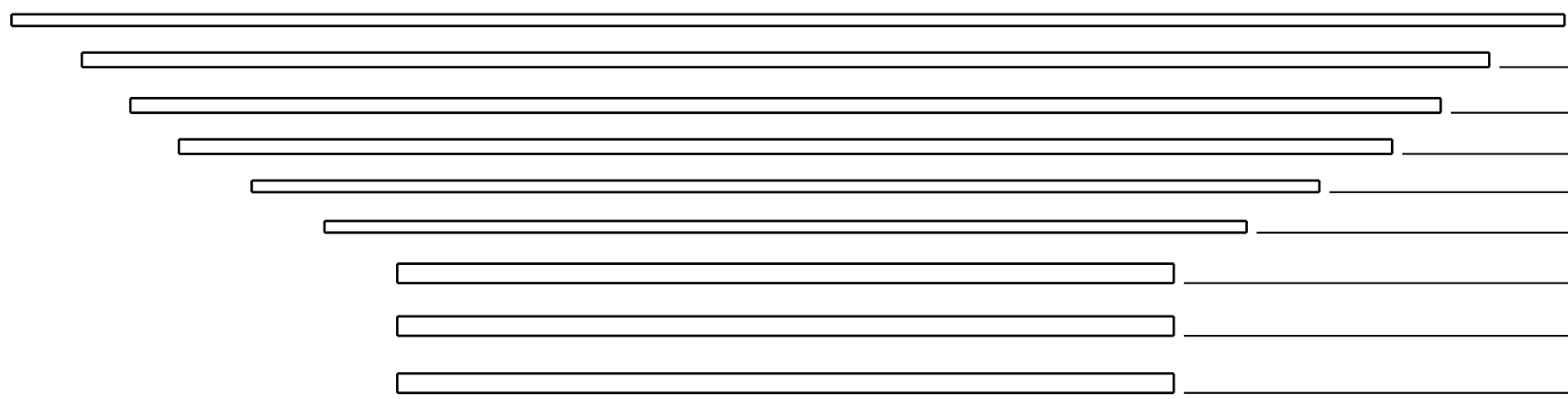
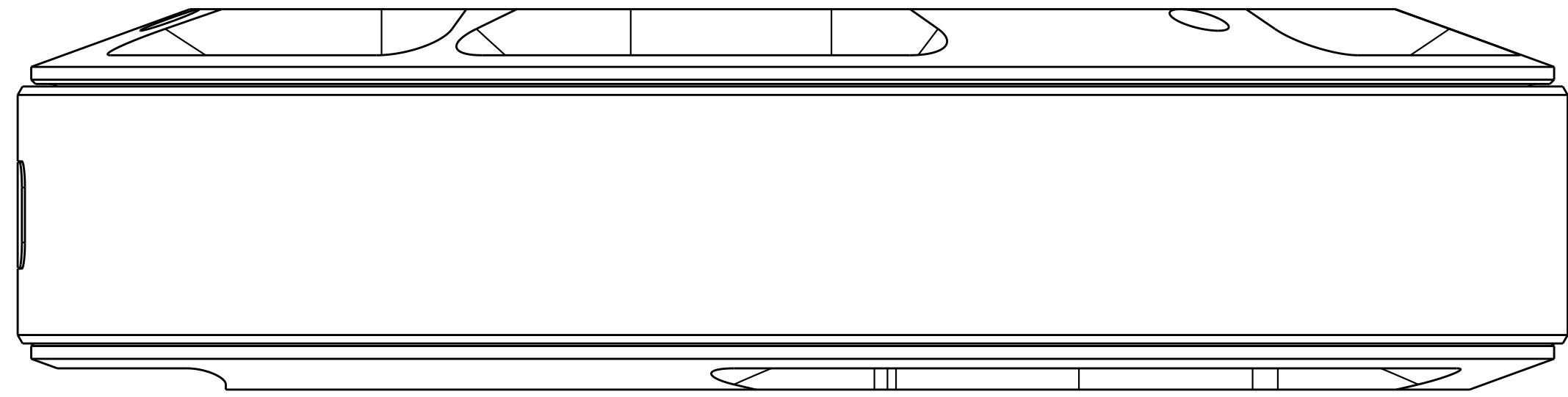

- 1.600 X .012
- 1.450 X .015
- 1.350 X .015
- 1.250 X .015
- 1.100 X .012
- .950 X .012
- .800 X .020
- .800 X .020
- .800 X .020

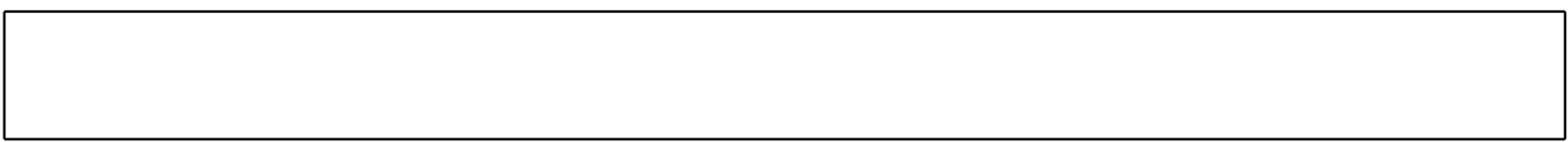

TOP-OUT WASHER

C

C

B

B

A

A

4

3

2

1

SIZE C	DWG. NO. 807-24-058	REV B
PLOT SCALE: 6:1		SHEET: 2 OF 2